

MABUCHI
MOTOR

RS-385PH

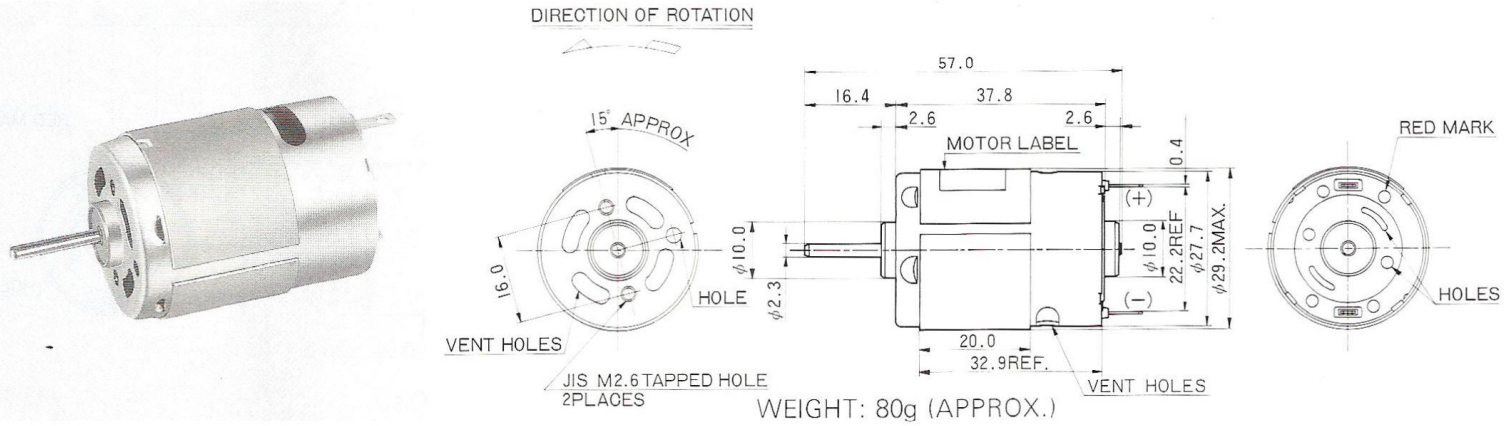

MODEL	VOLTAGE		NO LOAD		AT MAXIMUM EFFICIENCY						STALL TORQUE	
	OPERATING RANGE	NOMINAL	SPEED rpm	CURRENT A	SPEED rpm	CURRENT A	TORQUE oz-in	TORQUE g·cm	OUTPUT W	EFF %	oz-in	g·cm
RS-385PH-16140	12.0~30.0	24.0V CONSTANT	9100	0.09	7570	0.45	1.28	92.5	7.18	67.3	7.64	550
RS-385PH-2085	9.0~30.0	12.0V CONSTANT	7600	0.15	6140	0.63	1.07	76.9	4.84	64.0	5.56	400
RS-385PH-2085	9.0~30.0	24.0V CONSTANT	15200	0.17	12870	0.94	1.66	119.4	15.8	69.9	10.8	780
RS-385PH-2465	6.0~24.0	12.0V CONSTANT	9800	0.195	8180	0.99	1.31	94.0	7.89	66.6	7.92	570

RS-385PH-16140

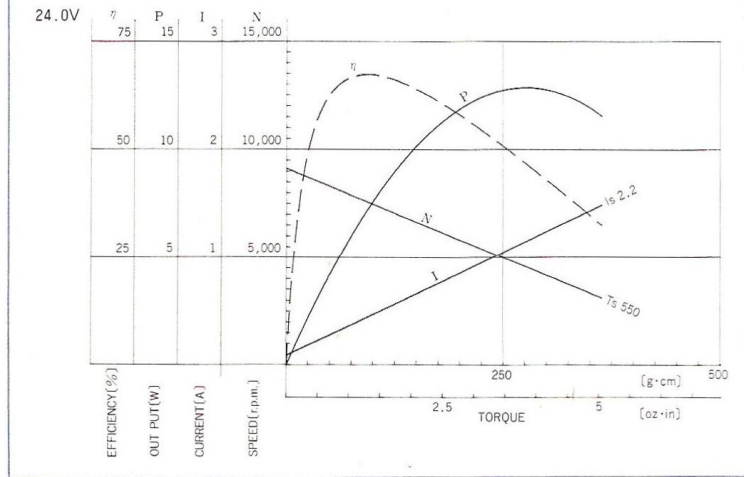

RS-385PH-2085

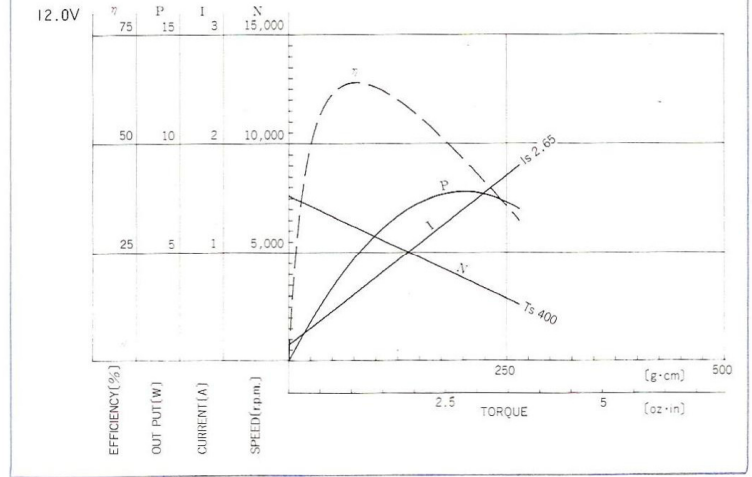

RS-385PH-2085

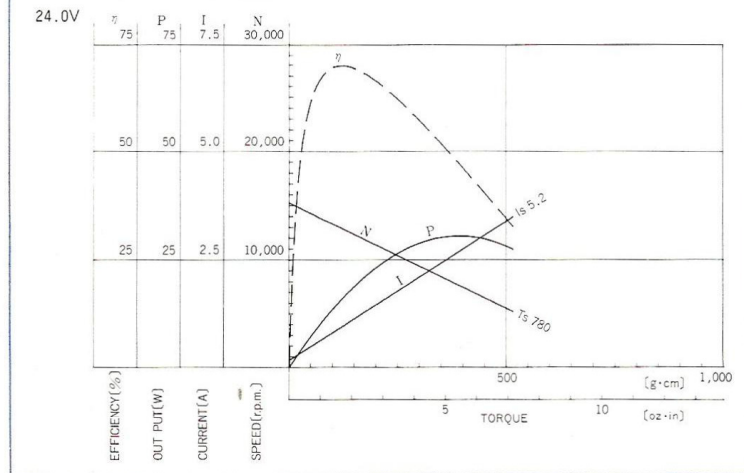

RS-385PH-2465

